

STANDARD TESTING OF PHOTOVOLTAIC MODULES FOR USE IN RENEWABLE ENERGY EDUCATION

David Agar & Jouko Korppi-Tommola

University of Jyväskylä, Department of Chemistry, P.O. Box 35, FIN-40014 Jyväskylä, Finland.

Abstract A photovoltaic laboratory exercise has been devised and used in the educational curriculum of the Renewable Energy Programme at the University of Jyväskylä. The purpose of the experimental tasks is to give students of renewable energy a good understanding of standard testing procedures used in industry for characterising photovoltaic modules and to provide practical skills in sizing simple photovoltaic installations. Herein the experimental set-up, basic theory and measurement procedure are described. The experimental apparatus is simple to assemble and uses both standard laboratory equipment and recycled components. From the experimental results, the tested PV cell had a maximum efficiency of 1.4 %, a fill factor of 0.58 and an electrical power production of 300 mW at the maximum power point of operation under standard testing irradiance of 1000 W/m². At this power output, the load resistance was 0.15 k Ω and module temperature was 25 \pm 2°C.

Keywords Education, photovoltaic modules, PV, standard test conditions

1 Introduction

The Renewable Energy (RE) Programme at the University of Jyväskylä (JYU) was initiated in 2003 as a multidisciplinary Master-level degree programme focusing on the RE sector. An important component of the curriculum is a laboratory course which aims to provide students with an understanding of the physical principles involved in renewable energy generation. A laboratory-scale Pelton wheel water turbine which demonstrates the principles of hydroelectric generation has been documented earlier (Agar & Rasi 2008). Here, an experiment using a photovoltaic (PV) cell is described. The purpose of the experiment is to introduce the student to standard test conditions of current and voltage measurements used in characterising photovoltaic modules – data which is customarily provided by manufacturers. From the measured data, several properties of a PV cell can be calculated and compared. This information can be used in planning simple photovoltaic installations.

Electromagnetic radiation from our sun (i.e. solar energy) is the driving force of all major renewable forms of energy on Earth. Outside of Earth's atmosphere, the extra-terrestrial irradiance of the sun is about 1367 W/m² being the absolute theoretical maximum available for terrestrial solar energy applications (and never achieved in practice).

Photovoltaic electrical generation is an ideal method of energy generation for many reasons. PV systems produce electricity silently, without emissions and are well-suited to the facades and rooftops of our cities. Furthermore, sunlight is a globally distributed energy source whose potential dwarfs the current rate of global energy consumption. PV generation will become increasingly important in future economies as manufacturing costs of PV

modules continue to decline due to technical innovations and mass production. The efficiency of commercial PV modules today is about 15% (Chopra et al. 2004).

2 Theory

The spectrum of solar radiation from our sun is rather broad and roughly corresponds to radiation within a wavelength range of 250 – 2000 nm. This corresponds to a range of photons of different energy.

P-n junctions form the basis of photovoltaic technology. A p-n junction is an interface between a p-type (positive) and n-type (negative) semiconductor material. The names come from the fact that n-type materials have an excess of negative charge carriers (electrons) while p-type materials have an excess of positive charge carriers (holes).

Photons incident on the n-type material of a p-n junction produce short-lived excitation of local electrons. These electrons can be utilised to do electrical work in a circuit connected across the junction. The potential gradient across the junction results in the flow of electrons in only one direction and consequently produces a direct current (DC) in the circuit.

PV cells, however, cannot utilise all the energy emitted by our sun. Photons of low-energy do not excite electrons sufficiently and photons of too high energy are reflected or their energy is dissipated by the re-emission of light. These effects mean that only about half of the solar spectrum is available to PV cells. This fact combined with other losses in real cells, limit efficiencies to some 25% in laboratory conditions (Nelson 2003).

The DC voltage produced from a single PV cell is in the range of 0.5 to 1 volt (Boyle 2004). Several cells can be connected electrically in series in order to create a module with a more useful output voltage of 12 volts. The current from a cell, or series connection of cells, can be increased by connecting it in parallel with another cell or series connection of cells. When several modules of cells are connected in parallel and enclosed in a casing, it is generally referred to as a PV module.

The current produced by a PV cell is a function of the solar *irradiance* (G) and the *surface area of the cell* (A). Overall performance of a cell depends on the circuit to which it is connected. When the electrical resistance of the circuit, connected between the terminals of the cell, is zero (short circuit conditions), the voltage difference is zero. In this case, the current flowing in the circuit is known as the *short-circuit current* (I_{sc}). When the resistance of the circuit is very large (open circuit conditions), the current is zero and the voltage between the cell's terminals is then known as the *open-circuit voltage* (U_{oc}).

The short-circuit current and the open-circuit voltage are depicted in the current-voltage plot for a p-n junction PV cell (figure 1) as the interception points of the y and x axis respectively. Current-voltage characteristics of an electric device are important for modelling its behaviour in real-life applications.

The instantaneous electrical power (P) produced by a PV cell is simply the product of the DC current (I) through and DC voltage (U) across the load resistance. The power at any point

STANDARD TESTING OF PHOTOVOLTAIC MODULES FOR USE IN RENEWABLE ENERGY EDUCATION

on the current-voltage plot is equivalent to the area of the rectangle drawn beneath that point (figure 1).

$$P = IU \quad (1)$$

Electrical power is greatest when the cell is operating at the *maximum power point* (subscript *m*) which is unique for a given load resistance. This corresponds to the point on the current-voltage curve where the area of a rectangle drawn beneath the curve is greatest.

The electrical energy (*E*) supplied by a PV cell which produces constant power *P* over a time duration *t* is

$$E = Pt = IUt \quad (2)$$

The fill factor (FF) describes how the current-voltage characteristics of a given cell compare to the ideal case, or in other words, the degree of squareness of the current-voltage curve. The closer the value of the fill factor is to unity, the better the performance of the PV cell.

$$FF = \frac{I_m U_m}{I_{sc} U_{oc}} \quad (3)$$

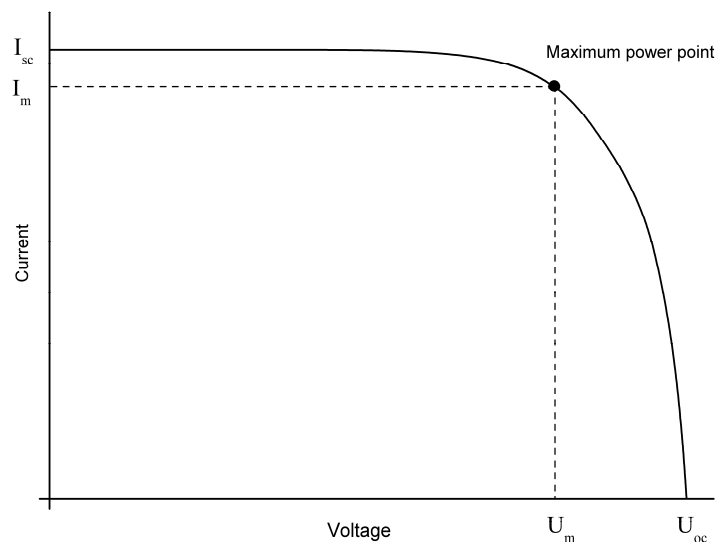

Figure 1. The electrical current produced through a p-n junction photovoltaic cell. The short-circuit current and open-circuit voltage are the values where the curve intersects the y and x axis respectively. The maximum power point on the curve is that which results in a maximum area of a rectangle drawn beneath the curve.

The efficiency of a PV cell can be expressed as:

$$\eta = \frac{P}{G \cdot A} \quad (4)$$

The SI units are [*P*] = W, [*G*] = W/m² and [*A*] = m².

Simple PV systems often use storage batteries in order to store electrical energy produced from a solar array in the form of chemical energy. The stored energy is then discharged according to electrical consumption. For lead batteries there are losses to be considered with

charging (subscript *c*) and discharging (subscript *d*). These losses can be taken into account by defining energy efficiency for the batteries.

$$\eta_E = \frac{E_d}{E_c} \quad (5)$$

3 Apparatus and methodology

Commercial PV modules are tested at Standard Test Conditions and module characteristics are generally provided by manufacturers. The reference conditions used in testing are: an air mass 1.5 spectrum and an irradiance of 1000 W/m² at a cell temperature of 25 degrees Celsius. These conditions can be approximated in the laboratory by use of a small PV cell, an artificial light source, and regulation of temperature.

The PV cell used has a size of roughly 15 x 15 cm² and is mounted on a plastic base fitted with terminals for electrical connections. Any functioning PV cell of modest dimensions (relative to the size of the light source) is suitable for use regardless of PV technology and age. The recycled cell used herein is old and hence has relatively poor efficiency compared to modern cells. However, the principle of measurement is the same.

A standard 500-Watt halogen lamp is used as a light source to illuminate the PV cell from above (figure 2). Irradiation intensity, which obeys an inverse-square law, can be varied by adjusting the height of the light source above the cell. The intensity at the surface of the PV cell is measured using a simple semiconductor-based intensity meter which is placed adjacent to the cell at an equal distance from the light source. Two salvaged PC cooling fans are used to improve air flow over the surface of the module in order to mitigate cell temperature, which generally remains at 25 ± 2°C. A standard laboratory 12 Volt DC power source supplies the fans. A K-type thermocouple, connected directly to a digital multi-meter with temperature readout function, is fixed to the side of the PV module in order to monitor cell temperature.

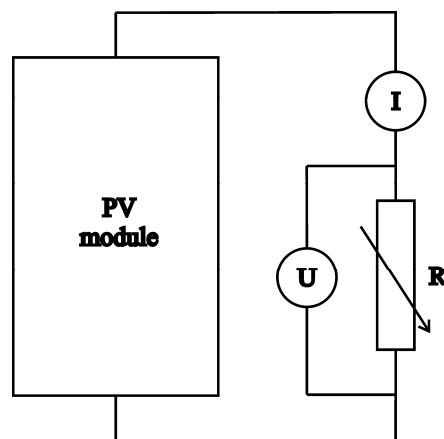

Figure 2. The measurement circuit used for standard testing of the PV cell.

The measurement circuit for characterising the PV cell is shown in figure 2. Voltage and current are measured using digital multi-meters. The load resistance (*R*) is an adjustable 0–100 kΩ decade resistor (Cambridge Instruments Co. Ltd.).

STANDARD TESTING OF PHOTOVOLTAIC MODULES FOR USE IN RENEWABLE ENERGY EDUCATION



Figure 3. Photograph of the experimental setup. The square 15 x 15 cm² PV cell is illuminated using a standard halogen lamp whose height (and irradiance) can be adjusted by means of a vertical steel support. Cooling fans can be seen to the left of the module. Resistance values can be dialled into the decade resistor, shown on the right.

Students conduct experiments with the PV module using three different irradiances; 1000, 500 and 200 W/m². Using the circuit shown in figure 2, the load resistance (R) is varied from zero to a value of 100 k Ω for each value of irradiation intensity. In order to obtain good current-voltage curves (I-V curves) at least 20 different values of resistance are used in the experiments and the corresponding current through and voltage across the resistor are recorded. Students are advised to obtain data points that show a well-defined curve especially in the region of the maximum power point. Care must be taken when using large irradiance due to excessive heating of the PV cell. Despite the use of cooling fans, cell temperature can rise well above 25 degrees Celsius if measurements are not carried out quickly. In such cases, the light source is switched off and measurements resumed after cooling. Uncertainties in the intensity meter reading are not taken into account in the data.

A comparison of the solar spectrum and the spectrum of the halogen lamp is also performed by the student. Using a miniature fibre optical spectrometer, students compare the spectra of daylight to that of the halogen lamp used in the measurements. They are asked to comment on how the artificial light source compares to natural sunlight.

Students are asked to consider a simple roof-top domestic PV system which includes lead storage batteries, modern charge controller (with maximum power point tracking ability), and an inverter for converting direct current to alternating current. Energy converted and stored in the 12-volt system is used on site with a daily household electrical consumption which varies between three and 10 kWh per day (space heating provided by other means).

Using the maximum power values for the PV cell and irradiance values for a typical solar day, the total number of cells (both in series and parallel) needed to supply this power, and associated losses, is found and the required surface area of the array is calculated. The minimum storage capacity of the batteries is also estimated.

For example, students are asked to consider an idealised solar day, which includes the irradiance with corresponding duration (*t*), as described in table 1 for the calculation.

Table 1. An example of data describing an idealised solar day.

G (W/m²)	t (hours)
1000	1.0
500	5.0
200	5.5

4 Results and discussion

Module performance will depend on the type and age of available modules. The current-voltage characteristics for three irradiance values are shown in figure 4 along with their corresponding power curves. Quantitative effects due to non-standard module temperature are not considered by students but a decrease in performance is clearly observed during IV-curve measurements as the light source causes heating of the module.

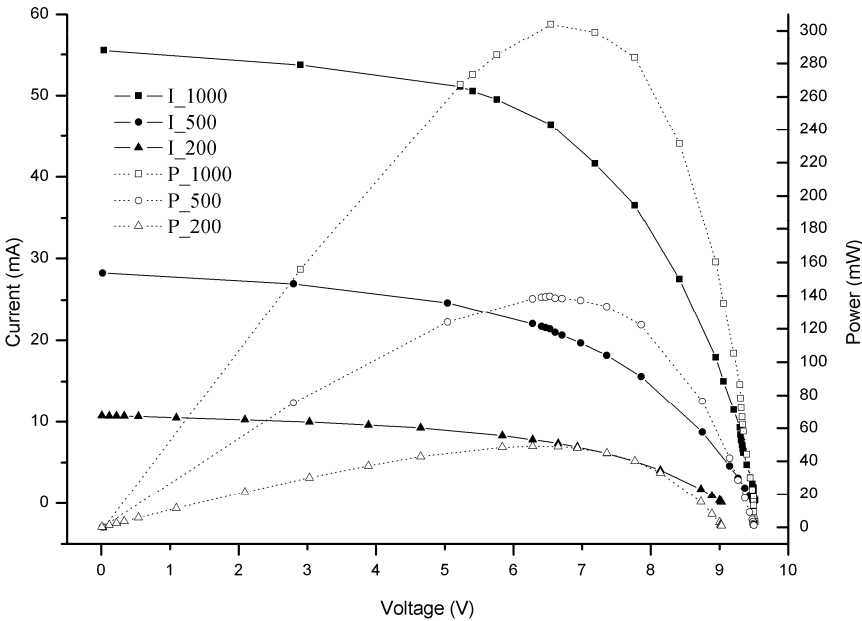

Figure 4. Measurement result for IV and power curves using the PV cell at three different irradiance values. Module temperature was maintained at 25 ± 2 °C.

Maximum power points are plotted as a function of irradiance in figure 5. By assuming a linear relationship between irradiance values and maximum electric output the energy produced from the PV cell for any described solar day can be found and used to calculate the required number of cells for supplying household energy consumption.

STANDARD TESTING OF PHOTOVOLTAIC MODULES
FOR USE IN RENEWABLE ENERGY EDUCATION

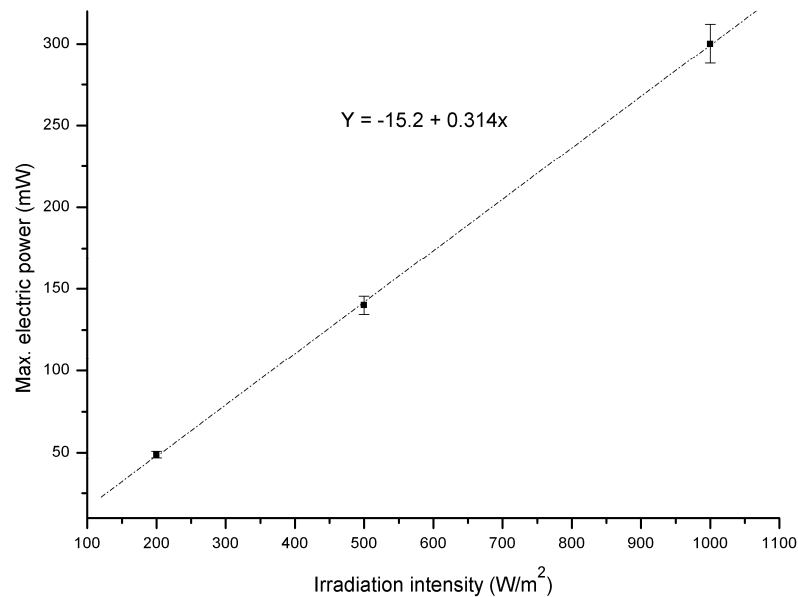

Figure 5. Maximum electrical power output of the PV cell as a function of irradiance. A linear fit has been performed using the three measured maximum values.

Table 2 displays key measured values of current and voltage at corresponding load resistance. The calculated fill factor and module efficiency are shown. Note that the efficiency of the recycled PV cell used herein (of unknown origin) is very low.

Table 2. Measurement results from testing of PV cell at three different irradiance values. The four columns on the right hold calculated values for maximum power, circuit resistance at maximum power point, fill factor and module efficiency.

G (W/m²)	I_{sc} (mA)	U_{oc} (V)	I_m (mA)	U_m (V)	P_m (mW)	R_m (kΩ)	FF	η
200	11	9.0	7.8	6.3	49	0.80	0.51	0.011
500	28	9.5	21	6.5	140	0.30	0.52	0.012
1000	56	9.5	46	6.6	300	0.15	0.58	0.014

The integer number of modules in series (m) required to supply the charging voltage (U_c) of the battery depends on the specific module used.

$$m = \frac{U_c}{U_m} \quad (6)$$

The cell voltage at maximum power point operation (U_m) can be assumed to be constant at all irradiance values. In practical lead-battery systems the required charging voltage is usually about 14 V.

The number of series-connected cells needed in parallel (n) to supply the electric demand is simply the needed charging energy divided by the energy produced from m cells. Using equation (5) and (6) and by assuming linear behaviour of the cell at maximum power points of operation, the following equation can be derived by the student.

$$n = \frac{E_c}{mE} = \frac{U_m E_d}{\eta_E U_c (P_{1000} t_1 + P_{500} t_2 + P_{200} t_3)} \quad (7)$$

In the denominator, the maximum power output of the cell at a specific value of G is given as P_x where x is the used irradiance and the duration (t) is in hours. The value of P at any irradiance can be found from a linearly fitted equation of the data as displayed in figure 5.

Knowing the total number of cells required, the surface area of the solar array can be found. For the cell described it is about 220 m². Students can then compare the required array size to one utilising modern commercial PV modules whose efficiency can be 15%. Using the known electric consumption and battery discharge voltage from equation 1 and 2 the battery capacity needed to store the daily energy consumption is found to be about 840 Ah.

Lastly, the wavelength distributions of the daylight and halogen lamp spectra are plotted in figure 6. The measured spectral count (intensity) of the two sources has been scaled in order to allow comparison of the two wavelength distributions. Qualitatively, students can observe that the artificial source has a spectral peak shifted towards the infrared by approximately 100 nm.

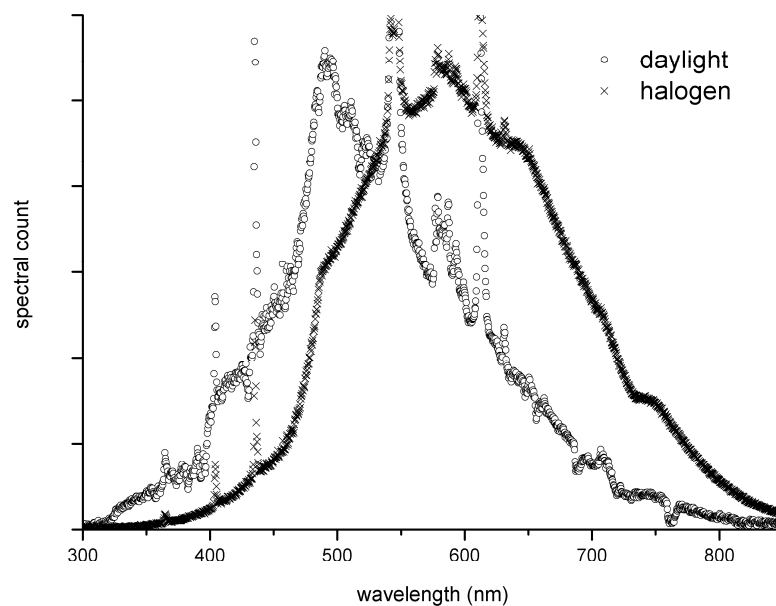

Figure 6. Qualitative comparison of daylight and 500-Watt halogen lamp spectra measured using a PC-connected miniature fibre optical spectrometer. The magnitudes of the spectral counts (intensity) of the two spectra have been scaled in order to compare wavelength distribution. The peaks occur at wavelengths of roughly 500 and 600 nanometres for daylight and halogen lamp respectively. The range of visible light is about 380-750 nm.

5 Conclusion

A photovoltaic laboratory exercise has been devised and used in the educational curriculum of the Renewable Energy Programme at the University of Jyväskylä. The experimental set-up, background material and measurement procedure are described with the aim of

STANDARD TESTING OF PHOTOVOLTAIC MODULES FOR USE IN RENEWABLE ENERGY EDUCATION

promoting education in renewable energy technologies. The experimental tasks are designed to give the student a good understanding of standard testing procedures used in industry for characterising photovoltaic modules and practical skills in sizing simple photovoltaic installations.

The p-n junction PV cell described and used herein had a maximum efficiency of 1.4 %, a fill factor of 0.58 and an electrical power production of 300 mW at the maximum power point of operation under standard testing irradiance of 1000 W/m². At this power output, the load resistance was 0.15 k Ω and module temperature was 25 \pm 2°C. For the example solar day given and a maximum household consumption of 10 kWh, the required surface area of the array is 220 m² and the minimum storage battery capacity is roughly 840 Ah.

Acknowledgements

Development of the laboratory component of the RE Programme's educational curriculum at JYU was supported financially by the European Social Fund. The authors would like to acknowledge Marko Rasi for initial development of the experimental tasks for the course component described herein.

References

- Agar, D. & Rasi, M. (2008). On the use of a laboratory-scale Pelton water wheel turbine in renewable energy education. *Renewable Energy* 33, 1517-1522.
- Chopra, K. L., Paulson, P. D., Dutta, V. (2004). Thin-Film Solar Cells: An Overview. *Progress in Photovoltaics* 12, 2-3; 69-92.
- Nelson, J. (2003). *The Physics of Solar Cells*. London: Imperial College Press, 363 pages.
- Boyle, G. (2004). *Renewable energy—power for a sustainable future*. Glasgow: Oxford University Press Inc.